



# TOLEDO FIRE & RESCUE DEPARTMENT



## C-14 Bus Emergencies

### Emergency Manual

**Date Revised: 02/01/2018**

Last Modified: 08/29/2024 15:38

[Export C14 to PDF](#)

[Export -Entire C Manual- to PDF](#)

---

### Policy/Procedure

One of the most important considerations when responding to a bus emergency is whether the bus has an air cushion ride. All TARTA and motor coach (Greyhound-style) buses have an air cushion ride.

BUSES MANUFACTURED WITH AN AIR CUSHION RIDE, HAVE A SUSPENSION THAT IS HELD UP BY AIR, NOT SPRINGS. IF THE AIR SYSTEM FAILS, THE BUS COULD DROP TO INCHES OFF THE GROUND. FIREFIGHTERS SHALL NOT WORK BENEATH A TARTA OR MOTOR COACH BUS UNLESS IT HAS BEEN APPROPRIATELY STABILIZED.

Common features of TARTA buses include:

- 1.** Battery compartments that are located on the driver's side just in front of the rear tires. The unlocking mechanism varies, but is clearly marked.
- 2.** Fuel tank fill openings that are located on the right side of the bus are just behind the front tire. Most are diesel powered with a 105-gallon tank capacity. The fuel tank runs the entire width of the bus, in the area of the tank fill.

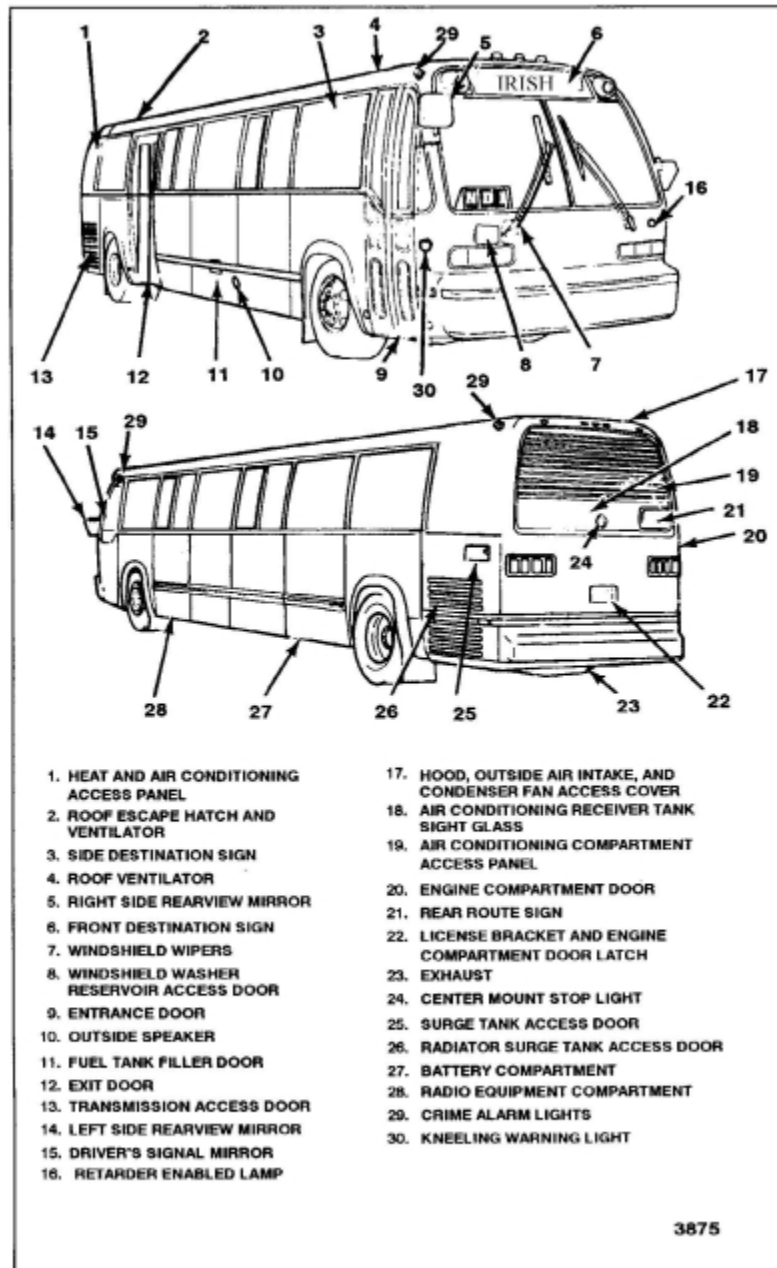

TARTA MODEL

3. There are normally two roof emergency escape hatches. These operate from the inside or outside.

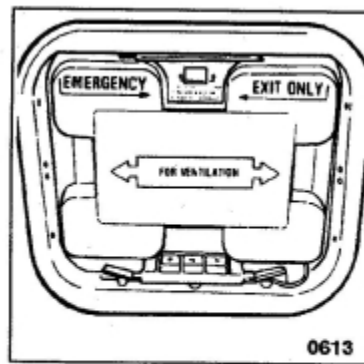

Roof Emergency Escape  
Found on all bus types.

4. A 12-volt system provides power for lights and 24-volt system powers the computer and starter.

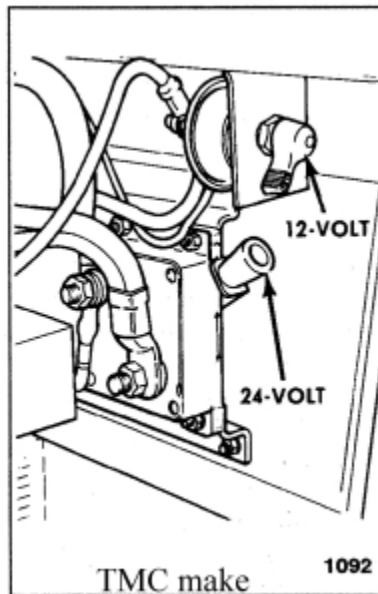

**Battery Disconnect Switches**



5. Some models possess a battery disconnect switch as pictured above.

6. Nearly all full-size buses have the engine in the rear. A door covering the engine compartment may need to be unlocked with a key in possession of the driver.

7. To gain entry in an emergency such as a fire or accident, the doors will not open unless the air

pressure used to operate them is released. The driver can show you where the emergency release is. If the driver is injured or gone, you will have to force entry.

## MOTOR COACH (GREYHOUND-STYLE) BUSES

1. Both the battery compartment and fuel tank fill on the motor coach bus are located on the right hand side.
2. Fuel capacity is usually 195 gallons for this style of bus.
3. There are two (2) roof hatches on board, and four (4) clearly marked emergency windows, operable from the inside.
4. Motor coach buses are normally rear engine powered.
5. Motor coach buses are very similar in appearance to the TARTA buses discussed above. Uses include commercial, charter, and private individual.

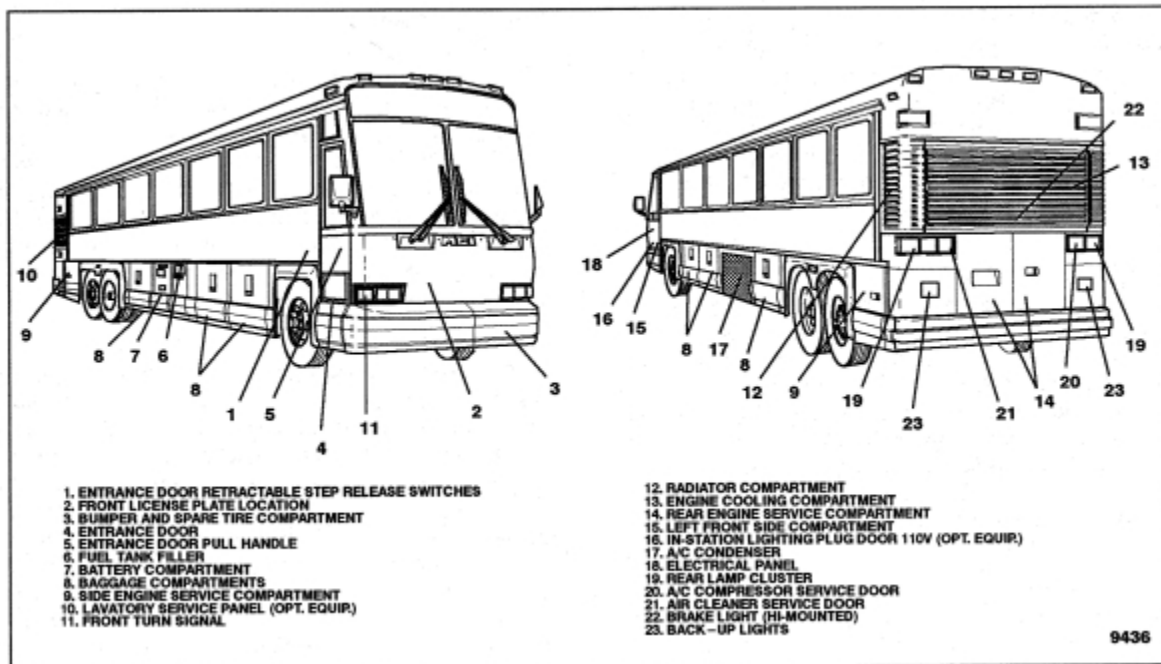

## SCHOOL BUS INFORMATION

1. There are some 30-gallon, gasoline powered, school buses left on the road. The majority of buses ordered now, are sixty-gallon diesel powered vehicles. The fuel tank themselves are protected by a barrier (or cage), or positioned between the frame rails. The location of the fuel tank fill is just behind the right, front entrance door.
2. School buses have roof hatches similar to those in the buses discussed earlier, and clearly marked emergency exit windows, inside the bus. All emergency doors and windows have an alarm buzzer that sounds upon opening. (Unless the battery is disconnected).

3. Some handicap-equipped school buses have an evacuation ramp located just below the rear emergency exit door.
4. School bus seats are made of a fire retardant material.
5. All school buses have rear emergency exit doors. Some may have another emergency exit door located amidships on the drivers' side of the bus.



School Bus during Emergency Hatch Operations

---

See Also:

---

Permanent link:

[https://tfrdweb.com/dokuwiki/doku.php?id=c\\_manual:c14](https://tfrdweb.com/dokuwiki/doku.php?id=c_manual:c14)

Last update: **08/29/2024 15:38**

